

Property Record Card

Clayton County Assessor

Mon, 7/14/2008, 4:50 PM Page 1

PDF+PIN: **005+41-22-254-002**
 Address **106 EAST MISSION STREET**
 (Property)
 City:
URBAN/COMMERCIAL

Deed: **FARMER, MICHAEL D.**
 Contract:
 CID#:
 DBA: **PRINCIPAL FINANCIAL GROUP**
 MLS:

Map Area: **STRAWBERRY PT-C**
 Route: **451-001-34A**
 Tax Dist: **STARMONT COMM**
 Plat Page: **19-17-22C**
 Subdiv: **[NONE]**

Checks/Tags:
 Lister/Date: **RE, 12/22/1999**
 Review/Date: **RE, 12/23/1999**
 Entry Status: **Inspected**

Legal: Section: ; Block/Twp: ; Lot/Rng: ; Deeded Acres: 0.000
 FRANKLIN ADDITION LOT 2 EXCEPT EAST 3' & WEST 4' OF BLOCK 4

Land

Land Basis	Front	Rear	Side 1	Side 2	R. Lot	SF	Acres	Depth Factor	EFF	Qual./Land						
FF Main	125.00	125.00	165.00	165.00	0.00			1.09	136.25	C-125						
Sub Total						20,625.00	0.474									
Grand Total						20,625.00	0.474									

Land Site Items

FF Main	Street: None	Utilities: None	Zoning: -- NONE --
----------------	--------------	-----------------	--------------------

Sales

Building Permits

Values

Date	\$ Amount	NUTC	Recording	Date	Number	Tag	\$ Amount	Reason	Type	Appraised	B of R	St. Equalized	Prior Yr: 2007
09/23/2002	\$0	D049	2002/3490						Land	\$18,053	\$0	\$0	\$18,053
06/10/1999	\$41,500	D019	1999-2157						Dwlg		\$0	\$0	
									Impr	\$45,013	\$0	\$0	\$45,013
									Total	\$63,066	\$0	\$0	\$63,066

Precomputed Structure		Verticals					Plumbing				
Occ. Code	501	Ftr & Fdtn	C'Blk or Tile	8"				Toilet Room	1		
Occ. Descr.	Office - General	Exterior wall	Alum - Frame	9				Sink-Kitchen	3		
		Interior wall	Plaster on Lath	8	Drywall or Equiv.	8					
		Pilasters									
		Wall facing	Face Brick Veneer	Average							
		Windows	Wood Casement	1							
		Fronts/Doors									
Year Built	1856										
EFF Age/Yr	151/ 1856										
Condition	OBSV										
Description	BLDG 1										
Style	Frame										
Stories	1										
Grade	5										
Base	1,630										
Basement	1,630										
GBA	1630										
		Horizontals									
		Basement	Incl. w / Base	Average							
		Roof	4-Ply Compo/ Wood Deck		Asph. Shingle/ Wood Dk						
		Ceiling	Plaster and Lath		Drywall						
		Struct. Floor	Concrete		Wd Joists w /Sub-Fir						
		Floor Cover	Carpet								
		Partitions	Office								
		Framing	Wood - Average	Average							
		HVAC	Combination FHA - AC	Average							
		Lighting	Office								
		Sprinkler									
							Adjustments				
							Brick Veneer (PLF)	32	AVE		

Bldg / Addn	Description	Units	Year
1 of 1	Bldg O 501 – Office - General		
	Pre P 501 – Office - General	1,630	
	V Ftr & Fdtn		
	C'Blk or Tile - 8"		
	V Exterior Wall		
	Alum - Frame - 9	9	
	V Interior Wall		
	Plaster on Lath - 8	8	
	Drywall or Equiv. - 8	8	
	V Wall Facing		
	Face Brick Veneer - Average		
	V Windows		
	Wood Casement - 1	1	
	H Basement		
	Incl. w / Base - Average	1,630	
	H Roof		
	4-Ply Compo/ Wood Deck	1,630	
	Asph. Shingle/ Wood Dk		
	H Ceiling		
	Plaster and Lath	1,630	
	Drywall		
	H Struct. Floor		
	Concrete	1,630	
	Wd Joists w /Sub-Flr		
	H Floor Cover		
	Carpet	1,630	
	H Partitions		
	Office	1,630	
	H Framing		
	Wood - Average - Average	1,630	
	H HVAC		
	Combination FHA - AC - Average	1,630	
	H Lighting		
	Office	1,630	
	Plmb Toilet Room - Base	1	
	Plmb Sink-Kitchen - Base	3	
	Adj Brick Veneer (PLF) - Average	32	
1 of 3	Ex Fireplace (Commercial)	1	1856
	1 Story Masonry		
2 of 3	Ex Porch (Commercial)	1	1856
	324 SF, Porch, Average Pricing		

3 of 3	Ex	Garage 420 SF, Metal, High Pricing	1	1856				
--------	----	---------------------------------------	---	------	--	--	--	--

Prior Year	Comment	Value Type	Land Value	Dwelling Value	Improvement Value	M & E Value	Total Value
2007		Appraised	\$18,053	\$0	\$45,013	\$0	\$63,066
2006		Appraised	\$18,053	\$0	\$40,775	\$0	\$58,828
2005		Appraised	\$18,053	\$0	\$40,775	\$0	\$58,828
2004		Equalized	\$18,053	\$0	\$40,775	\$0	\$58,828
2003		Equalized	\$18,053	\$0	\$40,775	\$0	\$58,828
2002		Appraised	\$17,031	\$0	\$38,467	\$0	\$55,498
2001		Appraised	\$17,031	\$0	\$38,467	\$0	\$55,498

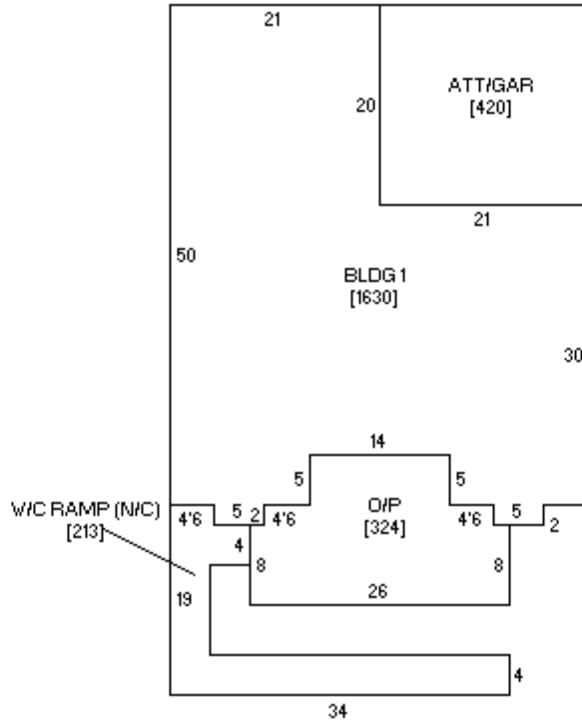

Sketch 1 of 1

